

INFISSO

serie Light 68

UNI EN 14351-1:2010

FINESTRA A DUE ANTE 1480 X 2180
SERIE: LIGHT 68
LEGNO TENERO

Resistenza al carico del vento: C2
Tenuta all'acqua: 9A
Sostanze pericolose: ASSENTI
Resistenza all'urto: CLASSE1
Capacità portante dei dispositivi di sicurezza: CONFORME
Prestazione acustica: 37 (-2); -5)dB
Trasmittanza termica: 1,4 W/m²K
Proprietà radiative: Trasmissione luminosa: 77%
Proprietà radiative: Fattore solare: 56%
Permeabilità all'aria: Classe 4

I suddetti valori sono indicativi e possono essere migliorati modificando il vetro, la canalina e la sezione dell'infisso, su richiesta della committenza;

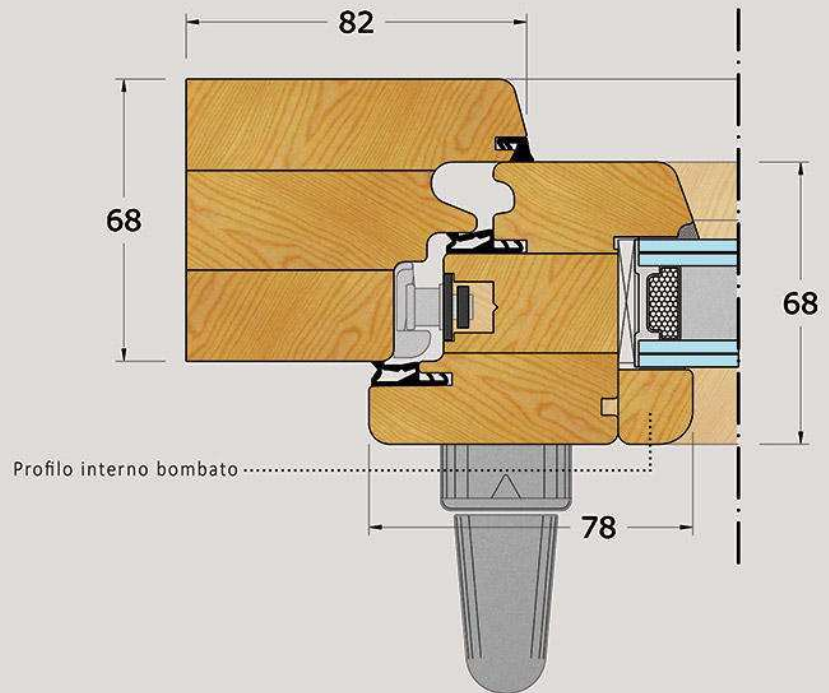

VETRI:

COMPOSIZIONE

33.1- 18mm Argon - 33.1 basso emissivo
(su richiesta inserimento di canalina warm edge)

PROPRIETA' TERMICHE EN 673
Valore Ug - W/(m².K) 1.1

LUCE
Trasmissione 77
Riflessione 12

ENERGIA
Fattore solare 56
Riflessione 23

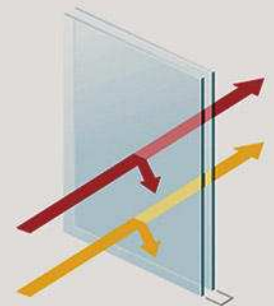

ESSENZE DISPONIBILI:



- pino lamellare lista intera
- pino lamellare finger joint
- abete lamellare lista intera
- abete lamellare finger joint
- mogano lamellare
- rovere lamellare

COLORI DISPONIBILI:



LACCATURA TINTA UNITA
con colori RAL a scelta

SU RICHIESTA:

- ESSENZE e COLORAZIONI differenti
- SPAZZOLATURA per PINO lista intera e ROVERE

MANIGLIE DK:



COPERTURA CERNIERE:



FORME SPECIALI

in legno

